

# GTL2009

## 3-bit GTL Front-Side Bus frequency comparator

Rev. 01 — 22 September 2005

Product data sheet

### 1. General description

---

The GTL2009 is designed for the Nocona and Dempsey/Blackford dual Intel Xeon processor platforms to compare the Front-Side Bus (FSB) frequency settings and set the common FSB frequency at the lowest setting if both processor slots are occupied or the FSB setting of the occupied processor slot if only one processor is being used. A default FSB frequency of 100 MHz is initially set upon power-up when  $V_{DD}$  is greater than 1.5 V.

Magnitude comparisons and frequency multiplexing to compute the common FSB frequency occurs when the two 3-bit FSB GTL inputs from the chip sets are valid. The common FSB frequency GTL outputs switch from the default frequency to the computed frequency when the GTL reference voltage input (VREF) crosses a static 0.6 V internally generated input comparator reference voltage. The GTL2009 then continually monitors the FSB frequency and slot occupied inputs for any further changes.

The Nocona and Dempsey/Blackford Xeon processors specify a  $V_{TT}$  of 1.2 V and 1.1 V, as well as a nominal  $V_{ref}$  of 0.76 V and 0.73 V respectively. To allow for future voltage level changes that may extend  $V_{ref}$  to 0.63 of  $V_{TT}$  (minimum of 0.693 V with  $V_{TT}$  of 1.1 V) the GTL2009 allows a minimum  $V_{ref}$  of 0.66 V. Characterization results show that there is little DC or AC performance variation between these levels.

The GTL2009 is a companion chip to the GTL2006 platform health management GTL-to-LVTTL translator and the newer GTL2007 that adds an enable function that disables the error output to the monitoring agent for platforms that monitor the individual error conditions from each processor.

### 2. Features

---

- Compares FSB frequency inputs to set the lowest frequency as the common bus frequency.
- Operates at a range of GTL signal levels
- 3.0 V to 3.6 V operation
- LVTTL I/O are not 5 V tolerant
- Companion chip to GTL2006 and GTL2007
- ESD protection exceeds 2000 V HBM per JESD22-A114, 200 V MM per JESD22-A115 and 1000 V CDM per JESD22-C101
- Latch-up testing is done to JEDEC Standard JESD78, which exceeds 500 mA
- Available in TSSOP16 package

**PHILIPS**

### 3. Quick reference data

**Table 1: Quick reference data**

$T_{amb} = 25^{\circ}C$

Symbol	Parameter	Conditions	Min	Typ	Max	Unit
$t_{PLH}$	LOW-to-HIGH propagation delay; BI to BO	$C_L = 30\text{ pF}$ ; $V_{DD} = 3.3\text{ V}$	3.0	16.5	30	ns
$t_{PHL}$	HIGH-to-LOW propagation delay; BI to BO		2.3	16.2	30	ns

### 4. Ordering information

**Table 2: Ordering information**

Type number	Topside mark	Package		
		Name	Description	Version
GTL2009PW	GTL2009	TSSOP16	plastic thin shrink small outline package; 16 leads; body width 4.4 mm	SOT403-1

### 5. Functional diagram

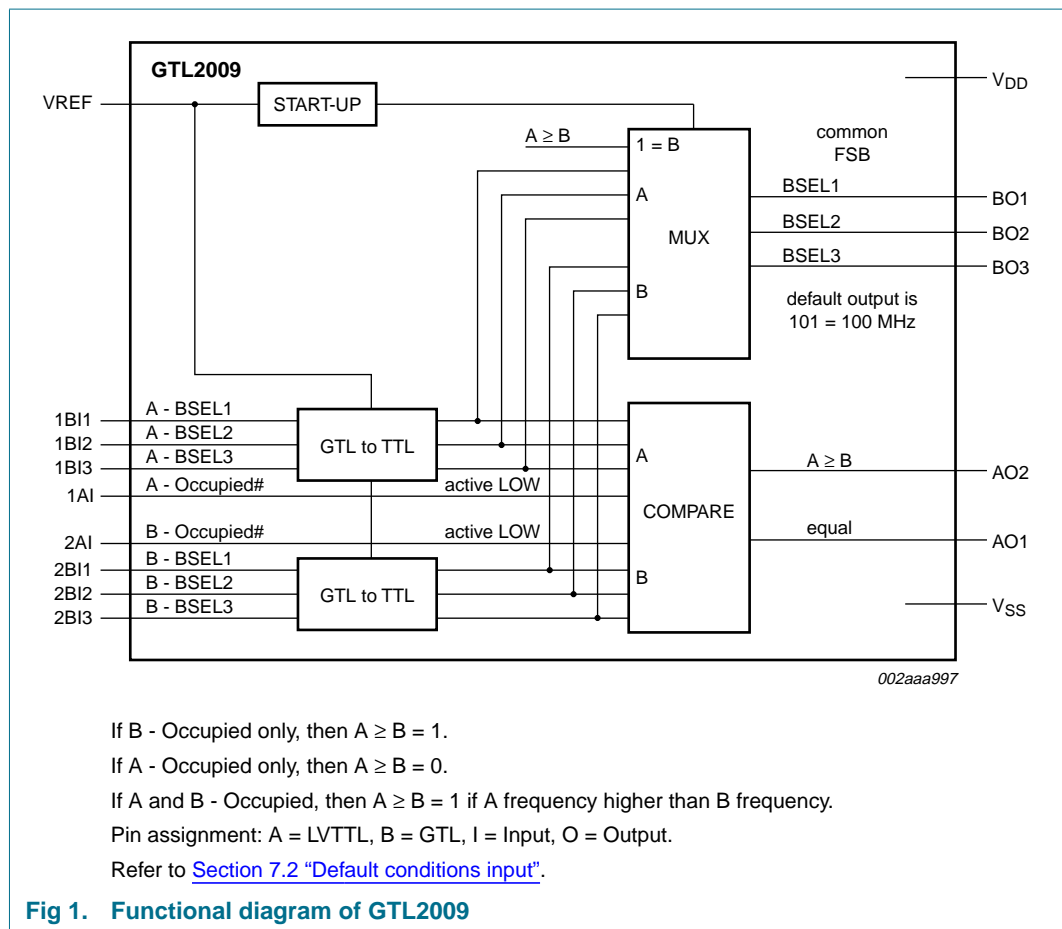

## 6. Pinning information

### 6.1 Pinning

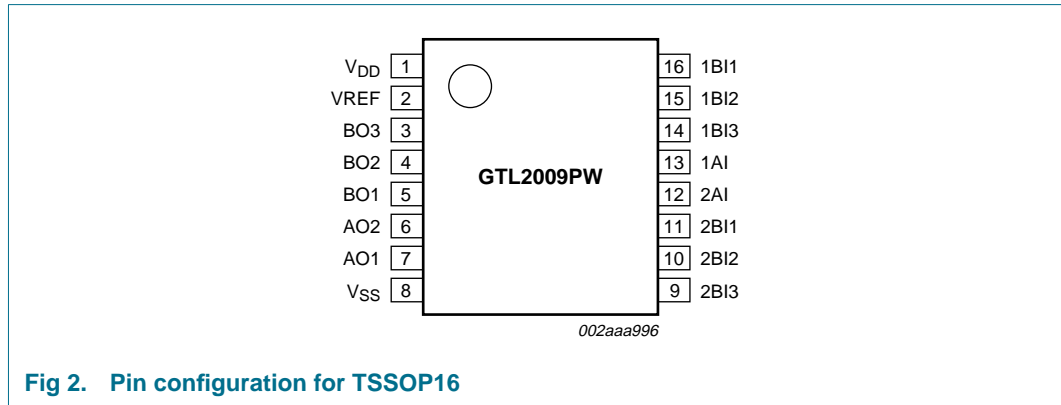

Fig 2. Pin configuration for TSSOP16

### 6.2 Pin description

Table 3: Pin description

Symbol	Pin	Type	Description
V <sub>DD</sub>	1	supply	supply voltage
VREF	2	V <sub>ref</sub>	V <sub>ref</sub> input voltage
BO3	3	GTL output	BSEL3
BO2	4	GTL output	BSEL2
BO1	5	GTL output	BSEL1
AO2	6	LVTTL output	A ≥ B
AO1	7	LVTTL output	equal
V <sub>SS</sub>	8	ground	ground supply
2BI3	9	GTL input	B-BSEL3
2BI2	10	GTL input	B-BSEL2
2BI1	11	GTL input	B-BSEL1
2AI	12	LVTTL input	B-occupied
1AI	13	LVTTL input	A-occupied
1BI3	14	GTL input	A-BSEL3
1BI2	15	GTL input	A-BSEL2
1BI1	16	GTL input	A-BSEL1

## 7. Functional description

Refer to [Figure 1 “Functional diagram of GTL2009”](#).

### 7.1 Function tables

**Table 4: FSB frequency selection**

BSEL3	BSEL2	BSEL1	FSB
H	L	H	100 MHz
L	L	H	133 MHz
L	H	H	166 MHz
L	H	L	200 MHz
L	L	L	266 MHz
H	L	L	333 MHz
H	H	L	400 MHz
H	H	H	reserved

**Table 5: FSB frequency comparison**

*Default on start-up is 101*

Processor A FSB	Processor B FSB	Pins BO1/BO2/BO3 Common FSB frequency
$A \geq B$	$A \geq B$	B
$A < B$	$A < B$	A
not occupied	B	B
A	not occupied	A
$A = B$	$A = B$	A or B

**Table 6: FSB the same output**

Processor A FSB	Processor B FSB	Compare A frequency = B frequency	Pin AO1
$A > B$	$A > B$	no	L
$A < B$	$A < B$	no	L
$A = B$	$A = B$	yes	H

**Table 7: FSB processor A greater than or equal to processor B output**

Pin 1AI	Pin 2AI	Compare A frequency > B frequency	Pin AO2		
A-occupied		B-occupied			
L	yes	L	yes	no	L
				yes	H
H	no	L	yes	X	H
L	yes	H	no	X	L
H	no	H	no	X	H

## 7.2 Default conditions input

The FSB GTL output data is masked and a specific default value (100 MHz) is inserted upon power-up when  $V_{DD}$  is greater than 1.5 V. The FSB GTL output data is unmasked and valid data is supplied when the VREF input crosses a static 0.6 V internally generated input comparator reference voltage. For slowly rising GTL  $V_{TT}$  supply (0.7 V/500  $\mu$ s), the switch-over happens at the 0.6 V threshold. For fast rising GTL  $V_{TT}$  supply (0.7 V/100 ns), the switch-over typically occurs between 350 ns to 1.5  $\mu$ s after the 0.6 V threshold is exceeded.

The AO1 and AO2 outputs do not have 'default conditions' like those assigned to the GTL outputs. Instead, these two pins will power-up according to the conditions applied to the 1A1 and 2A1 input pins as shown in [Table 8](#). If the slot is occupied, the input is LOW.

**Table 8: AO1 and AO2 power-up conditions**

*H = HIGH; L = LOW.*

1AI	2AI	$V_{DD}$	AO1	AO2
L	L	<1.5 V	L	L
L	L	>1.5 V	H	H
L	H	<1.5 V	L	L
L	H	>1.5 V	L	L
H	L	<1.5 V	L	L
H	L	>1.5 V	L	H
H	H	<1.5 V	L	L
H	H	>1.5 V	H	H

It is important to note that the AO1 and AO2 outputs may be valid a little before 1.5 V and will rise with  $V_{DD}$ . Valid outputs from the system level perspective will be achieved after  $V_{DD}$  is in regulation,  $V_{TT}$  ramps up, and after the internal propagation delay of the GTL2009. No firm answer for this can be given since the time it takes for  $V_{DD}$  to be in regulation varies from 100 ms to 1000 ms, and the rise time of  $V_{TT}$  is unknown. The GTL2009 outputs are valid after the GTL inputs are valid plus 19.6 ns (worst-case propagation delay of the GTL-to-LVTTL path).

## 8. Application design-in information

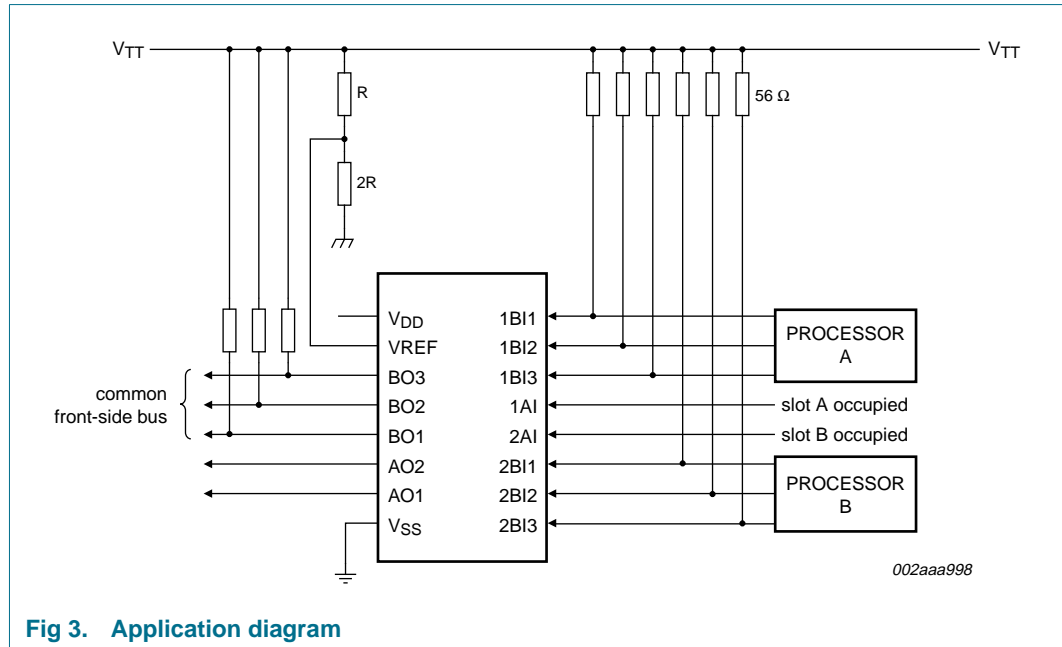

Fig 3. Application diagram

### 8.1 Frequently asked questions

**Question 1:** When the GTL2009 is unpowered, the LVTTL inputs may be pulled up to 3.3 V and we want to make sure that there is no leakage path to the power rail under this condition. Are the LVTTL inputs high-impedance when the device is unpowered and will there be any leakage?

**Answer 1:** When the device is unpowered, the LVTTL inputs will be in a high-impedance state and will not leak to  $V_{DD}$  if they are pulled HIGH or LOW while the device is unpowered.

**Question 2:** What is the condition of the GTL and LVTTL output pins when the device is unpowered?

**Answer 2:** The open-drain GTL outputs will not leak to the power supply if they are pulled HIGH or allowed to float while the device is unpowered. The GTL inputs will also not leak to the power supply under the same conditions. The LVTTL totem pole outputs, however, are not open-drain type outputs and there will be current flow on these pins if they are pulled HIGH when  $V_{DD}$  is at ground.

## 9. Limiting values

**Table 9: Limiting values**

In accordance with the Absolute Maximum Rating System (IEC 60134). [1]

Voltages are referenced to  $V_{SS}$  (ground = 0 V).

Symbol	Parameter	Conditions	Min	Max	Unit
$V_{DD}$	supply voltage		-0.5	+4.6	V
$I_{IK}$	input clamping current	$V_I < 0$ V	-	-50	mA
$V_I$	input voltage	A port (LVTTL)	[3] -0.5	+4.6	V
		B port (GTL)	[3] -	-50	mA
$I_{OK}$	output clamping current	$V_O < 0$ V	-	-50	mA
$V_O$	output voltage	output in Off or HIGH state; A port	[3] -0.5	+4.6	V
		output in Off or HIGH state; B port	[3] -0.5	+4.6	V
$I_{OL}$	LOW-state output current [4]	A port	-	24	mA
		B port	-	30	mA
$I_{OH}$	HIGH-state output current [5]	A port	-	-24	mA
$T_{stg}$	storage temperature		-60	+150	°C
$T_j$	junction temperature		[2] -	+125	°C

- [1] Stresses beyond those listed may cause permanent damage to the device. These are stress ratings only and functional operation of the device at these or any other conditions beyond those indicated under [Section 10 "Recommended operating conditions"](#) is not implied. Exposure to absolute-maximum-rated conditions for extended periods may affect device reliability.
- [2] The performance capability of a high-performance integrated circuit in conjunction with its thermal environment can create junction temperatures which are detrimental to reliability. The maximum junction temperature of this integrated circuit should not exceed 150 °C.
- [3] The input and output negative voltage ratings may be exceeded if the input and output clamp current ratings are observed.
- [4] Current into any output in the LOW state.
- [5] Current into any output in the HIGH state.

## 10. Recommended operating conditions

**Table 10: Recommended operating conditions**

Symbol	Parameter	Conditions	Min	Typ	Max	Unit
$V_{DD}$	supply voltage		3.0	3.3	3.6	V
$V_{TT}$	termination voltage	GTL	-	1.2	-	V
$V_{ref}$	reference voltage	GTL	0.66	0.8	1.1	V
$V_I$	input voltage	A port	0	3.3	3.6	V
		B port	0	$V_{TT}$	3.6	V
$V_{IH}$	HIGH-state input voltage	A port	2	-	-	V
		B port	$V_{ref} + 0.050$	-	-	V
$V_{IL}$	LOW-state input voltage	A port	-	-	0.8	V
		B port	-	-	$V_{ref} - 0.050$	V
$I_{OH}$	HIGH-state output current	A port	-	-	-12	mA
$I_{OL}$	LOW-state output current	A port	-	-	12	mA
		B port	-	-	15	mA
$T_{amb}$	ambient temperature	operating in free air	-40	-	+85	°C

## 11. Static characteristics

**Table 11: Static characteristics**

Over recommended operating conditions. Voltages are referenced to  $V_{SS}$  (ground = 0 V).  $T_{amb} = -40^{\circ}\text{C}$  to  $+85^{\circ}\text{C}$ .

Symbol	Parameter	Conditions	Min	Typ <sup>[1]</sup>	Max	Unit
$V_{OH}$	HIGH-level output voltage; A port	$V_{DD} = 3.0\text{ V}$ to $3.6\text{ V}$ ; $I_{OH} = -100\ \mu\text{A}$	<sup>[2]</sup> $V_{DD} - 0.2$	2.99	-	V
		$V_{DD} = 3.0\text{ V}$ ; $I_{OH} = -16\text{ mA}$	<sup>[2]</sup> 2.1	2.37	-	V
$V_{OL}$	LOW-level output voltage; A port	$V_{DD} = 3.0\text{ V}$ ; $I_{OL} = 8\text{ mA}$	<sup>[2]</sup> -	0.27	0.4	V
		$V_{DD} = 3.0\text{ V}$ ; $I_{OL} = 12\text{ mA}$	<sup>[2]</sup> -	0.4	0.55	V
	LOW-level output voltage; B port	$V_{DD} = 3.0\text{ V}$ ; $I_{OL} = 15\text{ mA}$	<sup>[2]</sup> -	0.11	0.4	V
$I_I$	input current; A port	$V_{DD} = 3.6\text{ V}$ ; $V_I = V_{DD}$	-	-	$\pm 1$	$\mu\text{A}$
		$V_{DD} = 3.6\text{ V}$ ; $V_I = 0\text{ V}$	-	-	$\pm 1$	$\mu\text{A}$
	input current; B port	$V_{DD} = 3.6\text{ V}$ ; $V_I = V_{TT}$ or $V_{SS}$	-	-	$\pm 1$	$\mu\text{A}$
$I_{LO}$	output leakage current; B port	$V_{DD} = 3.6\text{ V}$ ; $V_O = V_{TT}$	-	-	$\pm 1$	$\mu\text{A}$
$I_{DD}$	supply current; A or B port	$V_{DD} = 3.6\text{ V}$ ; $V_I = V_{DD}$ or $V_{SS}$ ; $I_O = 0\text{ mA}$	-	5.5	10	mA
$\Delta I_{DD}$	additional quiescent supply current; A port or control inputs	$V_{DD} = 3.6\text{ V}$ ; $V_I = V_{DD} - 0.6\text{ V}$	<sup>[3]</sup> -	32	500	$\mu\text{A}$
$C_{io}$	input/output capacitance; A port	$V_O = 3.0\text{ V}$ or $0\text{ V}$	-	7.8	-	pF
	input/output capacitance; B port	$V_O = V_{TT}$ or $0\text{ V}$	-	4.5	-	pF

[1] All typical values are measured at  $V_{DD} = 3.3\text{ V}$  and  $T_{amb} = 25^{\circ}\text{C}$ .

[2] The input and output voltage ratings may be exceeded if the input and output current ratings are observed.

[3] This is the increase in supply current for each input that is at the specified LVTTTL voltage level, rather than  $V_{DD}$  or  $V_{SS}$ .



## 12. Dynamic characteristics

**Table 12: Dynamic characteristics**

$V_{DD} = 3.3 V \pm 0.3 V$

Symbol	Parameter	Conditions	Limits						Unit
			$V_{ref} = 0.73 V;$ $V_{TT} = 1.1 V$			$V_{ref} = 0.76 V;$ $V_{TT} = 1.2 V$			
			Min	Typ [1]	Max	Min	Typ [1]	Max	
$t_{PLH}$	LOW-to-HIGH propagation delay; AI to AO	<a href="#">Figure 4</a> and <a href="#">Figure 8</a>	1.4	7.9	14.5	1.4	7.8	14.5	ns
$t_{PHL}$	HIGH-to-LOW propagation delay; AI to AO	<a href="#">Figure 8</a>	2.0	9.0	16.0	2.0	8.8	16.0	ns
$t_{PLH}$	LOW-to-HIGH propagation delay; BI to AO	<a href="#">Figure 6</a>	2.6	16.3	30.0	2.5	16.5	30.5	ns
$t_{PHL}$	HIGH-to-LOW propagation delay; BI to AO		2.8	13.9	25.0	2.9	14.0	25.0	ns
$t_{PLH}$	LOW-to-HIGH propagation delay; BI to BO	<a href="#">Figure 7</a>	3.0	16.5	30.0	3.0	16.5	30.0	ns
$t_{PHL}$	HIGH-to-LOW propagation delay; BI to BO		2.3	16.2	30.0	2.3	16.2	30.0	ns
$t_{PLH}$	LOW-to-HIGH propagation delay; AI to BO	<a href="#">Figure 5</a>	2.1	7.9	14.0	2.0	8.3	14.5	ns
$t_{PHL}$	HIGH-to-LOW propagation delay; AI to BO		1.4	7.3	13.5	1.5	7.7	14.0	ns

[1] All typical values are at  $V_{DD} = 3.3 V$  and  $T_{amb} = 25 ^\circ C$ .

12.1 AC waveforms

$V_M = 1.5\text{ V}$  at  $V_{DD} \geq 3.0\text{ V}$  for A ports;  $V_M = V_{ref}$  for B ports.

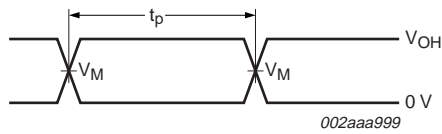

$V_M = 1.5\text{ V}$  for A port and  $V_{ref}$  for B port.  
 $V_{OH} = 3\text{ V}$  for A port and  $V_{TT}$  for B port  
 $t_p$  = pulse duration

Fig 4. Pulse duration

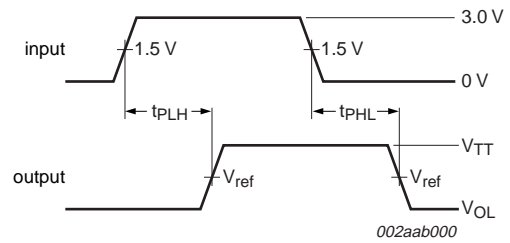
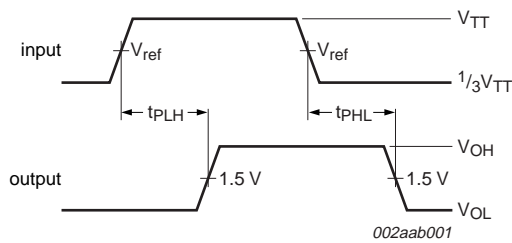

Fig 5. Propagation delay, A port to B port



$PRR \leq 10\text{ MHz}$ ;  $Z_o = 50\ \Omega$ ;  $t_r \leq 2.5\text{ ns}$ ;  $t_f \leq 2.5\text{ ns}$

Fig 6. Propagation delay, BI to AO

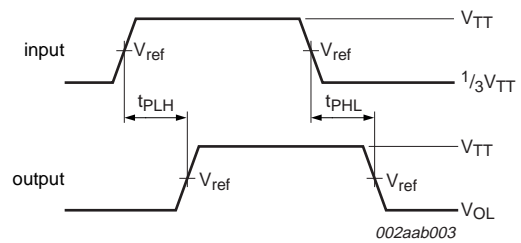

Fig 7. Propagation delay, BI to BO

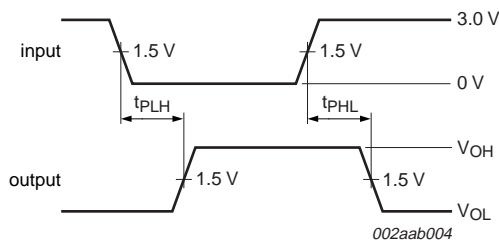

Fig 8. Propagation delay, AI to AO

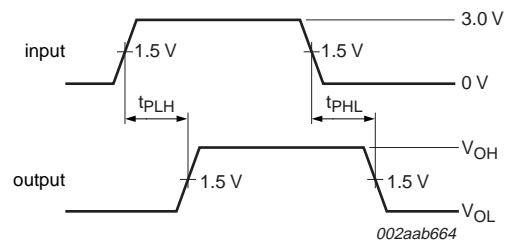

Fig 9. Propagation delay, 1AI to AO2

## 13. Test information

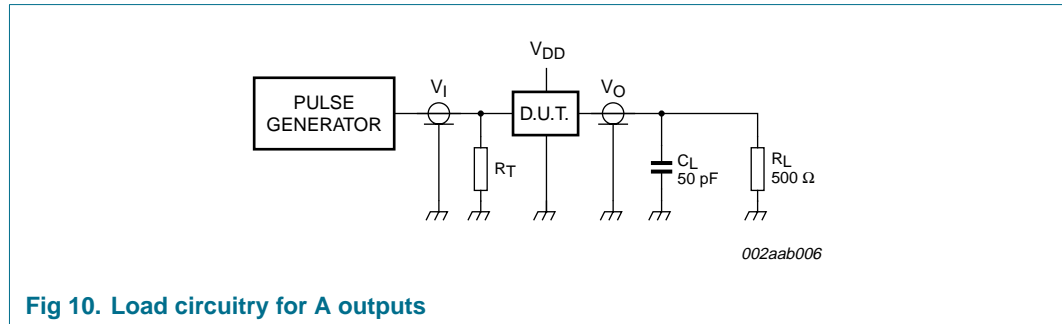

Fig 10. Load circuitry for A outputs

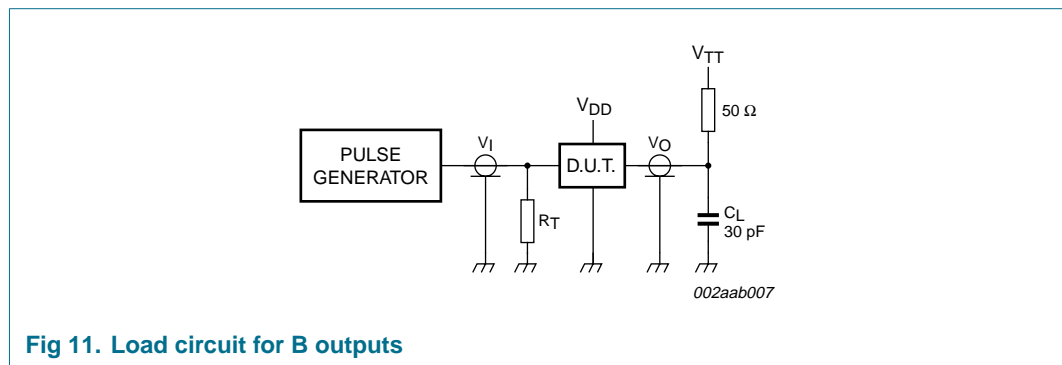

Fig 11. Load circuit for B outputs

Definitions:

 $R_L$  — load resistor $C_L$  — load capacitance includes jig and probe capacitance. $R_T$  — termination resistance should be equal to  $Z_o$  of pulse generators.

14. Package outline

TSSOP16: plastic thin shrink small outline package; 16 leads; body width 4.4 mm

SOT403-1

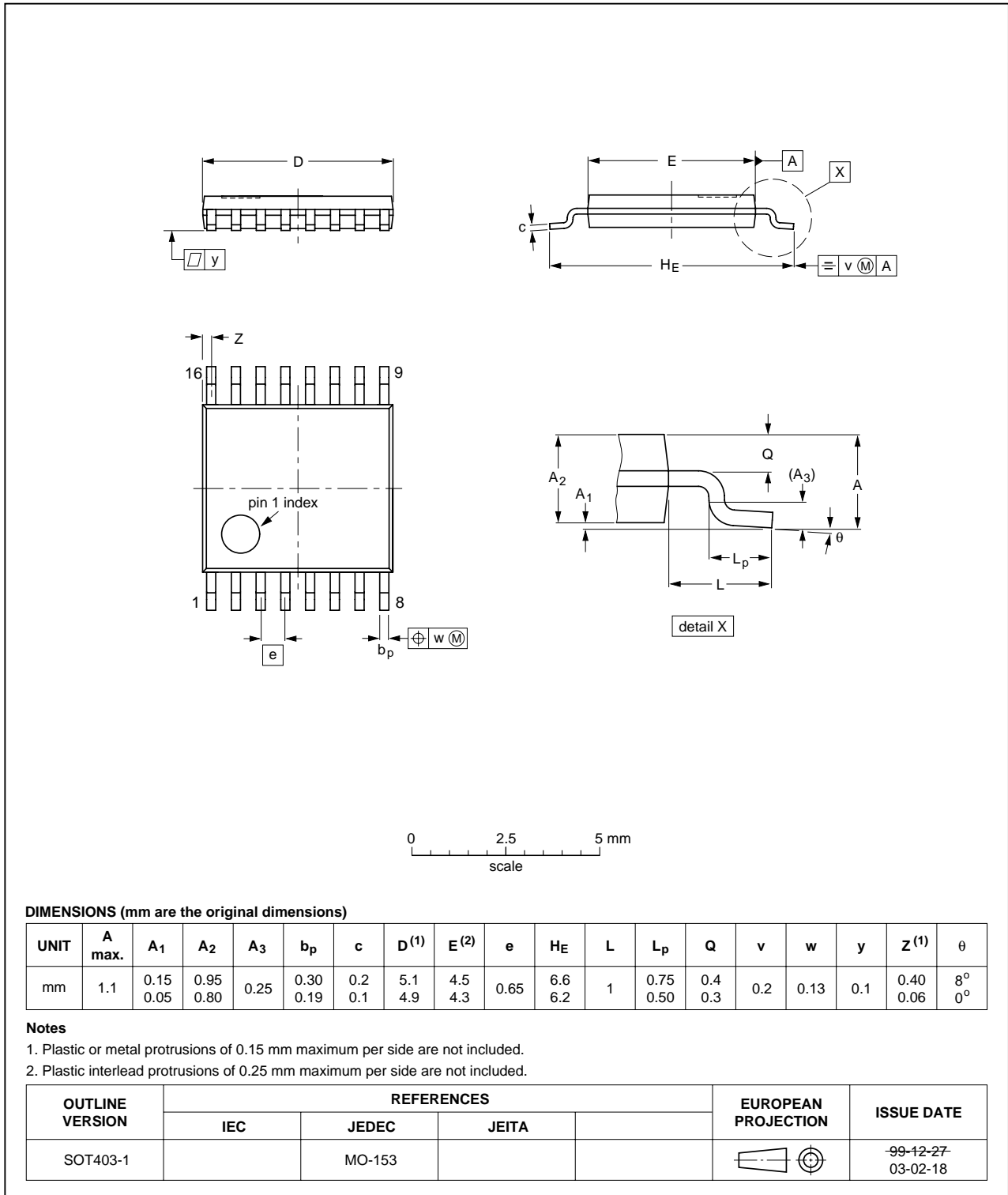

Fig 12. Package outline SOT403-1 (TSSOP16)

## 15. Soldering

### 15.1 Introduction to soldering surface mount packages

This text gives a very brief insight to a complex technology. A more in-depth account of soldering ICs can be found in our *Data Handbook IC26; Integrated Circuit Packages* (document order number 9398 652 90011).

There is no soldering method that is ideal for all surface mount IC packages. Wave soldering can still be used for certain surface mount ICs, but it is not suitable for fine pitch SMDs. In these situations reflow soldering is recommended.

### 15.2 Reflow soldering

Reflow soldering requires solder paste (a suspension of fine solder particles, flux and binding agent) to be applied to the printed-circuit board by screen printing, stencilling or pressure-syringe dispensing before package placement. Driven by legislation and environmental forces the worldwide use of lead-free solder pastes is increasing.

Several methods exist for reflowing; for example, convection or convection/infrared heating in a conveyor type oven. Throughput times (preheating, soldering and cooling) vary between 100 seconds and 200 seconds depending on heating method.

Typical reflow peak temperatures range from 215 °C to 270 °C depending on solder paste material. The top-surface temperature of the packages should preferably be kept:

- below 225 °C (SnPb process) or below 245 °C (Pb-free process)
  - for all BGA, HTSSON..T and SSOP..T packages
  - for packages with a thickness  $\geq 2.5$  mm
  - for packages with a thickness  $< 2.5$  mm and a volume  $\geq 350$  mm<sup>3</sup> so called thick/large packages.
- below 240 °C (SnPb process) or below 260 °C (Pb-free process) for packages with a thickness  $< 2.5$  mm and a volume  $< 350$  mm<sup>3</sup> so called small/thin packages.

Moisture sensitivity precautions, as indicated on packing, must be respected at all times.

### 15.3 Wave soldering

Conventional single wave soldering is not recommended for surface mount devices (SMDs) or printed-circuit boards with a high component density, as solder bridging and non-wetting can present major problems.

To overcome these problems the double-wave soldering method was specifically developed.

If wave soldering is used the following conditions must be observed for optimal results:

- Use a double-wave soldering method comprising a turbulent wave with high upward pressure followed by a smooth laminar wave.
- For packages with leads on two sides and a pitch (e):
  - larger than or equal to 1.27 mm, the footprint longitudinal axis is **preferred** to be parallel to the transport direction of the printed-circuit board;

- smaller than 1.27 mm, the footprint longitudinal axis **must** be parallel to the transport direction of the printed-circuit board.

The footprint must incorporate solder thieves at the downstream end.

- For packages with leads on four sides, the footprint must be placed at a 45° angle to the transport direction of the printed-circuit board. The footprint must incorporate solder thieves downstream and at the side corners.

During placement and before soldering, the package must be fixed with a droplet of adhesive. The adhesive can be applied by screen printing, pin transfer or syringe dispensing. The package can be soldered after the adhesive is cured.

Typical dwell time of the leads in the wave ranges from 3 seconds to 4 seconds at 250 °C or 265 °C, depending on solder material applied, SnPb or Pb-free respectively.

A mildly-activated flux will eliminate the need for removal of corrosive residues in most applications.

## 15.4 Manual soldering

Fix the component by first soldering two diagonally-opposite end leads. Use a low voltage (24 V or less) soldering iron applied to the flat part of the lead. Contact time must be limited to 10 seconds at up to 300 °C.

When using a dedicated tool, all other leads can be soldered in one operation within 2 seconds to 5 seconds between 270 °C and 320 °C.

## 15.5 Package related soldering information

**Table 13: Suitability of surface mount IC packages for wave and reflow soldering methods**

Package <sup>[1]</sup>	Soldering method	
	Wave	Reflow <sup>[2]</sup>
BGA, HTSSON..T <sup>[3]</sup> , LBGA, LFBGA, SQFP, SSOP..T <sup>[3]</sup> , TFBGA, VFBGA, XSON	not suitable	suitable
DHVQFN, HBCC, HBGA, HLQFP, HSO, HSOP, HSQFP, HSSON, HTQFP, HTSSOP, HVQFN, HVSON, SMS	not suitable <sup>[4]</sup>	suitable
PLCC <sup>[5]</sup> , SO, SOJ	suitable	suitable
LQFP, QFP, TQFP	not recommended <sup>[5]</sup> <sup>[6]</sup>	suitable
SSOP, TSSOP, VSO, VSSOP	not recommended <sup>[7]</sup>	suitable
CWQCCN..L <sup>[8]</sup> , PMFP <sup>[9]</sup> , WQCCN..L <sup>[8]</sup>	not suitable	not suitable

[1] For more detailed information on the BGA packages refer to the *(LF)BGA Application Note (AN01026)*; order a copy from your Philips Semiconductors sales office.

[2] All surface mount (SMD) packages are moisture sensitive. Depending upon the moisture content, the maximum temperature (with respect to time) and body size of the package, there is a risk that internal or external package cracks may occur due to vaporization of the moisture in them (the so called popcorn effect). For details, refer to the Drypack information in the *Data Handbook IC26; Integrated Circuit Packages; Section: Packing Methods*.

[3] These transparent plastic packages are extremely sensitive to reflow soldering conditions and must on no account be processed through more than one soldering cycle or subjected to infrared reflow soldering with peak temperature exceeding 217 °C ± 10 °C measured in the atmosphere of the reflow oven. The package body peak temperature must be kept as low as possible.

- [4] These packages are not suitable for wave soldering. On versions with the heatsink on the bottom side, the solder cannot penetrate between the printed-circuit board and the heatsink. On versions with the heatsink on the top side, the solder might be deposited on the heatsink surface.
- [5] If wave soldering is considered, then the package must be placed at a 45° angle to the solder wave direction. The package footprint must incorporate solder thieves downstream and at the side corners.
- [6] Wave soldering is suitable for LQFP, QFP and TQFP packages with a pitch (e) larger than 0.8 mm; it is definitely not suitable for packages with a pitch (e) equal to or smaller than 0.65 mm.
- [7] Wave soldering is suitable for SSOP, TSSOP, VSO and VSSOP packages with a pitch (e) equal to or larger than 0.65 mm; it is definitely not suitable for packages with a pitch (e) equal to or smaller than 0.5 mm.
- [8] Image sensor packages in principle should not be soldered. They are mounted in sockets or delivered pre-mounted on flex foil. However, the image sensor package can be mounted by the client on a flex foil by using a hot bar soldering process. The appropriate soldering profile can be provided on request.
- [9] Hot bar soldering or manual soldering is suitable for PMFP packages.

## 16. Abbreviations

**Table 14: Abbreviations**

Acronym	Definition
CDM	Charged Device Model
ESD	Electrostatic Discharge
FSB	Front-Side Bus
GTL	Gunning Transceiver Logic
HBM	Human Body Model
LVTTTL	Low Voltage Transistor-Transistor Logic
MM	Machine Model
PRR	Pulse Rate Repetition

## 17. Revision history

**Table 15: Revision history**

Document ID	Release date	Data sheet status	Change notice	Doc. number	Supersedes
GTL2009_1	20050922	Product data sheet	-	9397 750 13556	-

## 18. Data sheet status

Level	Data sheet status <sup>[1]</sup>	Product status <sup>[2] [3]</sup>	Definition
I	Objective data	Development	This data sheet contains data from the objective specification for product development. Philips Semiconductors reserves the right to change the specification in any manner without notice.
II	Preliminary data	Qualification	This data sheet contains data from the preliminary specification. Supplementary data will be published at a later date. Philips Semiconductors reserves the right to change the specification without notice, in order to improve the design and supply the best possible product.
III	Product data	Production	This data sheet contains data from the product specification. Philips Semiconductors reserves the right to make changes at any time in order to improve the design, manufacturing and supply. Relevant changes will be communicated via a Customer Product/Process Change Notification (CPCN).

[1] Please consult the most recently issued data sheet before initiating or completing a design.

[2] The product status of the device(s) described in this data sheet may have changed since this data sheet was published. The latest information is available on the Internet at URL <http://www.semiconductors.philips.com>.

[3] For data sheets describing multiple type numbers, the highest-level product status determines the data sheet status.

## 19. Definitions

**Short-form specification** — The data in a short-form specification is extracted from a full data sheet with the same type number and title. For detailed information see the relevant data sheet or data handbook.

**Limiting values definition** — Limiting values given are in accordance with the Absolute Maximum Rating System (IEC 60134). Stress above one or more of the limiting values may cause permanent damage to the device. These are stress ratings only and operation of the device at these or at any other conditions above those given in the Characteristics sections of the specification is not implied. Exposure to limiting values for extended periods may affect device reliability.

**Application information** — Applications that are described herein for any of these products are for illustrative purposes only. Philips Semiconductors make no representation or warranty that such applications will be suitable for the specified use without further testing or modification.

## 20. Disclaimers

**Life support** — These products are not designed for use in life support appliances, devices, or systems where malfunction of these products can reasonably be expected to result in personal injury. Philips Semiconductors

## 22. Contact information

For additional information, please visit: <http://www.semiconductors.philips.com>

For sales office addresses, send an email to: [sales.addresses@www.semiconductors.philips.com](mailto:sales.addresses@www.semiconductors.philips.com)

customers using or selling these products for use in such applications do so at their own risk and agree to fully indemnify Philips Semiconductors for any damages resulting from such application.

**Right to make changes** — Philips Semiconductors reserves the right to make changes in the products - including circuits, standard cells, and/or software - described or contained herein in order to improve design and/or performance. When the product is in full production (status 'Production'), relevant changes will be communicated via a Customer Product/Process Change Notification (CPCN). Philips Semiconductors assumes no responsibility or liability for the use of any of these products, conveys no license or title under any patent, copyright, or mask work right to these products, and makes no representations or warranties that these products are free from patent, copyright, or mask work right infringement, unless otherwise specified.

## 21. Trademarks

**Notice** — All referenced brands, product names, service names and trademarks are the property of their respective owners.



## 23. Contents

<b>1</b>	<b>General description</b> .....	<b>1</b>
<b>2</b>	<b>Features</b> .....	<b>1</b>
<b>3</b>	<b>Quick reference data</b> .....	<b>2</b>
<b>4</b>	<b>Ordering information</b> .....	<b>2</b>
<b>5</b>	<b>Functional diagram</b> .....	<b>2</b>
<b>6</b>	<b>Pinning information</b> .....	<b>3</b>
6.1	Pinning .....	3
6.2	Pin description .....	3
<b>7</b>	<b>Functional description</b> .....	<b>4</b>
7.1	Function tables .....	4
7.2	Default conditions input .....	5
<b>8</b>	<b>Application design-in information</b> .....	<b>6</b>
8.1	Frequently asked questions .....	6
<b>9</b>	<b>Limiting values</b> .....	<b>7</b>
<b>10</b>	<b>Recommended operating conditions</b> .....	<b>7</b>
<b>11</b>	<b>Static characteristics</b> .....	<b>8</b>
<b>12</b>	<b>Dynamic characteristics</b> .....	<b>9</b>
12.1	AC waveforms .....	10
<b>13</b>	<b>Test information</b> .....	<b>11</b>
<b>14</b>	<b>Package outline</b> .....	<b>12</b>
<b>15</b>	<b>Soldering</b> .....	<b>13</b>
15.1	Introduction to soldering surface mount packages .....	13
15.2	Reflow soldering .....	13
15.3	Wave soldering .....	13
15.4	Manual soldering .....	14
15.5	Package related soldering information .....	14
<b>16</b>	<b>Abbreviations</b> .....	<b>15</b>
<b>17</b>	<b>Revision history</b> .....	<b>15</b>
<b>18</b>	<b>Data sheet status</b> .....	<b>16</b>
<b>19</b>	<b>Definitions</b> .....	<b>16</b>
<b>20</b>	<b>Disclaimers</b> .....	<b>16</b>
<b>21</b>	<b>Trademarks</b> .....	<b>16</b>
<b>22</b>	<b>Contact information</b> .....	<b>16</b>



© Koninklijke Philips Electronics N.V. 2005

All rights are reserved. Reproduction in whole or in part is prohibited without the prior written consent of the copyright owner. The information presented in this document does not form part of any quotation or contract, is believed to be accurate and reliable and may be changed without notice. No liability will be accepted by the publisher for any consequence of its use. Publication thereof does not convey nor imply any license under patent- or other industrial or intellectual property rights.

Date of release: 22 September 2005  
Document number: 9397 750 13556

Published in The Netherlands